

RANCO

Lightweight

BOTTOM DUMP DOUBLES

simply the best



AR-250 Abrasion Resistant 115,000 lb. Minimum Sheeting

RANCO DUMP DOUBLES FEATURE:

- Maximize Payload
- Minimize Maintenance
- 3-Year Warranty

RANCO LIGHTWEIGHT BOTTOM DUMP DOUBLES

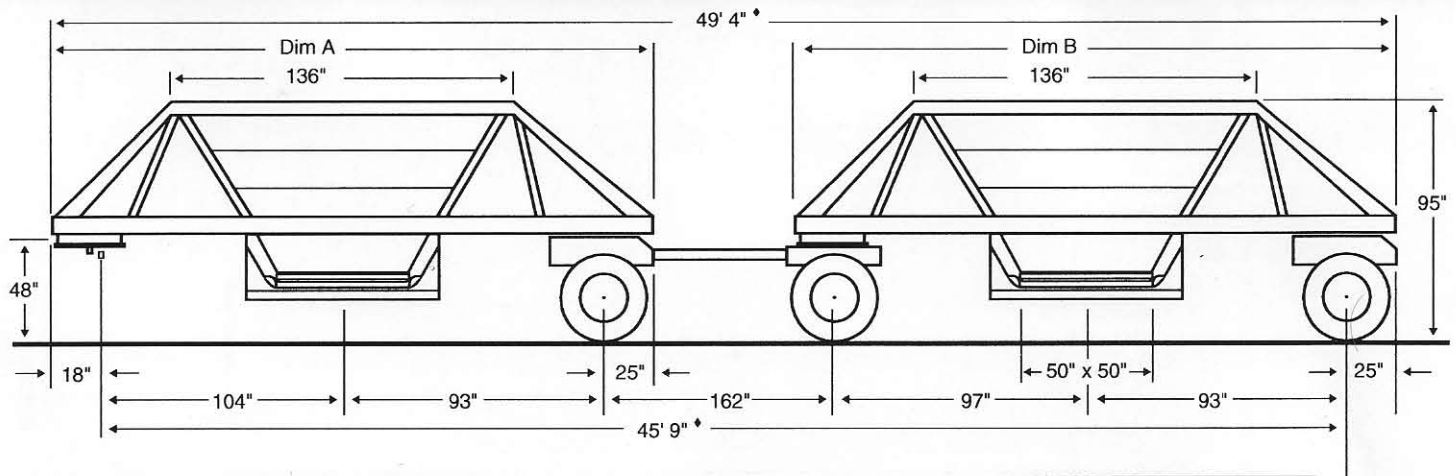

MODEL	CAPACITY	DIMENSION A	DIMENSION B	GATE SIZE	SET WEIGHT *
LW11-20S & P	22 CU YDS	240"	234"	50" x 50"	12,970 LBS
LW12-21S & P	24 CU YDS	254"	248"	60" x 72"	13,475 LBS

* Weight PLUS or MINUS 3% with standard equipment. Other weights available with options

♦ Dimension varies depending on drawbar length

MORE STANDARD EQUIPMENT THAN ANY OTHER TRAILER ON THE MARKET...

LW11-20 & LW12-21 SEMI AND PULL TRAILER STANDARD EQUIPMENT

MAIN FRAME

- AR-250 Abrasion Resistant Steel Sheeting — 115,000 lb. minimum yield
- Hi-Tensile Tubular Steel Frame — 80,000 lb. minimum yield
- Bolt-on Fiberglass Fenders, Front & Rear with Mud Flaps
- Bolt-on Fiberglass Shed Plates, Front & Rear
- 18" Steel Wings
- 8" Wood Top off Boards

SUSPENSION & AXLES

- Hutchens – H9700 Suspension with Single Low Arch Springs
- Meritor 22,500 lb. 5" Tubular Axles w/ Stemco Seals
- 16.5" X 7" Air Brakes w/ Auto Slack Adjusters
- Meritor-Wabco ABS Brake System
- Outboard Hubs w/ Centrifuse Drums
- 8.25 X 22.5 Steel Disk Wheels
- 11R X 22.5 Michelin Steel Radial Tires

GATE & AIR SYSTEM

- Heavy Duty Composite 5" gate cylinders
- Compression Side Gate Seals & End Seals
- Versa Control Valve with Cab and Ground Control
- Air Filter, Oil Lubricator & Air Gage

ELECTRICAL & SAFETY EQUIPMENT

- Circuit Breaker Protected Sealed Lights
- Wiring In Safety Loom and Enclosed in Trailer Frame
- Air Cushioned Pintle Hook w/ Safety Cables
- Center Mud Flap in Front of Axles
- Ranco White Paint

OPTIONAL EQUIPMENT

- Different Size Gates
- 8" Aluminum Top Offs
- Tarps – All Types
- Aluminum Hubs
- Aluminum Wheels – Duals & Singles
- Super Single Michelin Tires
- Special Paint