

# TRANCO

## General Purpose

# BELLY DUMPS

*simply the best*



# **RANCO** *General Purpose California Special*

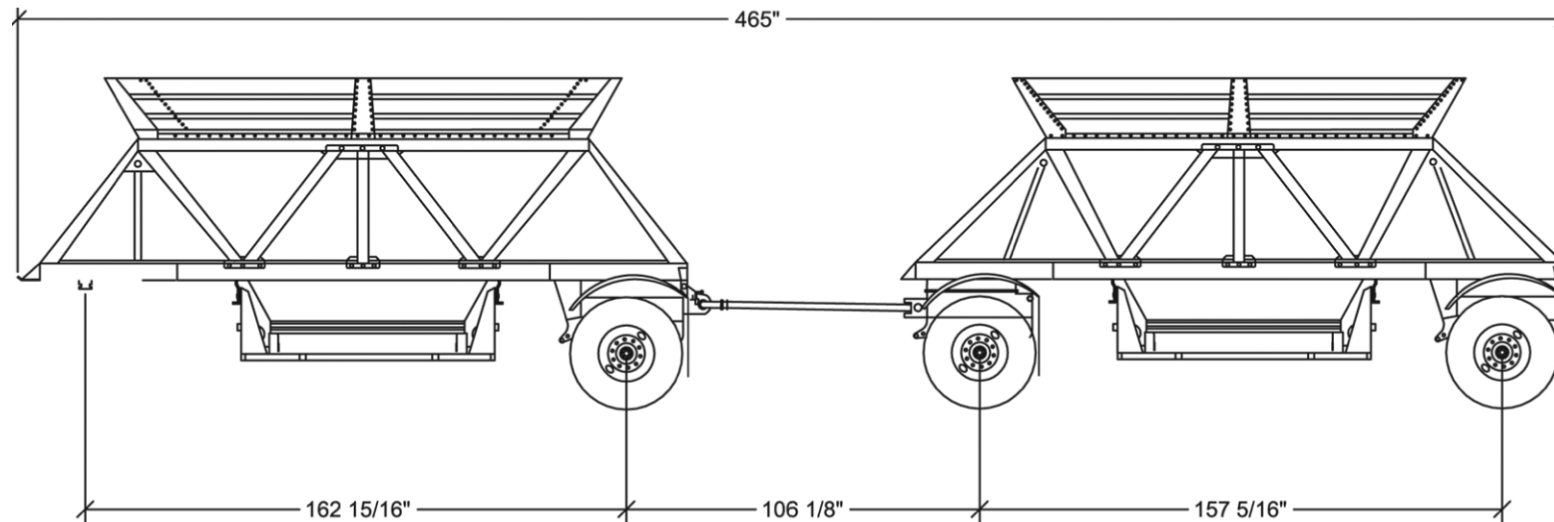

**Capacity: 24 cubic yards (approximately)**  
• **Weight: 13,400 lbs. (approximately)**  
• **Paint: Polyurethane**  
• **Gates: Windrow Type; Gate end 10 gauge Hi-tensile Gate bottom 10 gauge Hi-tensile with 4"x4" reinforcement Twin composite barrel air cylinder actuators Adjustable chains front and rear**  
• **Skins: 12 gauge Hi-tensile steel**  
• **Shedplates: 14 gauge steel, welded on**  
• **Bang Boats: 2"x10" wood bolted on**  
• **Turnable Fenders: Steel Weld On**  
• **Gate Controls: Versa Valve on left side, electrically actuated from truck cab**

- **Gate Hoses: Hoses are 1/2" with one quick release valve per cylinder**
- **Gate Seals: Steel welded on exterior of gates**
- **Electrical: DOT approved 12 volt sealed lighting system**
- **Plumbing: DOT approved system**
- **Under Mount: Three leaf springs, 36" German turntable double bearing**
- **Axles: 5" diameter with oil seals. 22,500 lbs. capacity, 71.5" track**
- **Drums: Centrifuge outboard drums**
- **Brakes: ABS braking system, 16.5"x7" Scam type, auto slack adjusters**
- **Drawbar: 87" long, square tubing, cast steel hinged bracket, rubber bused, 2.375" ID swivel type eyebolt with safety cable**
- **Wheels: 11 x 22.5 or 11 x 24.5 Steel Disc.**

*Ranco reserves the right to change designs, materials and specifications without notice or incurring any obligation to such change.*

**RANCO TRAILERS • P.O. BOX 856 • LAMAR, COLORADO 81052**  
**(719) 336-9041 • FAX (719) 336-5952 • USA TOLL FREE 800-631-5708**