

RENCO

ALUMINIUM

BELLY DUMPS

Simply the best



RANCO *Plant To Plant California Special*

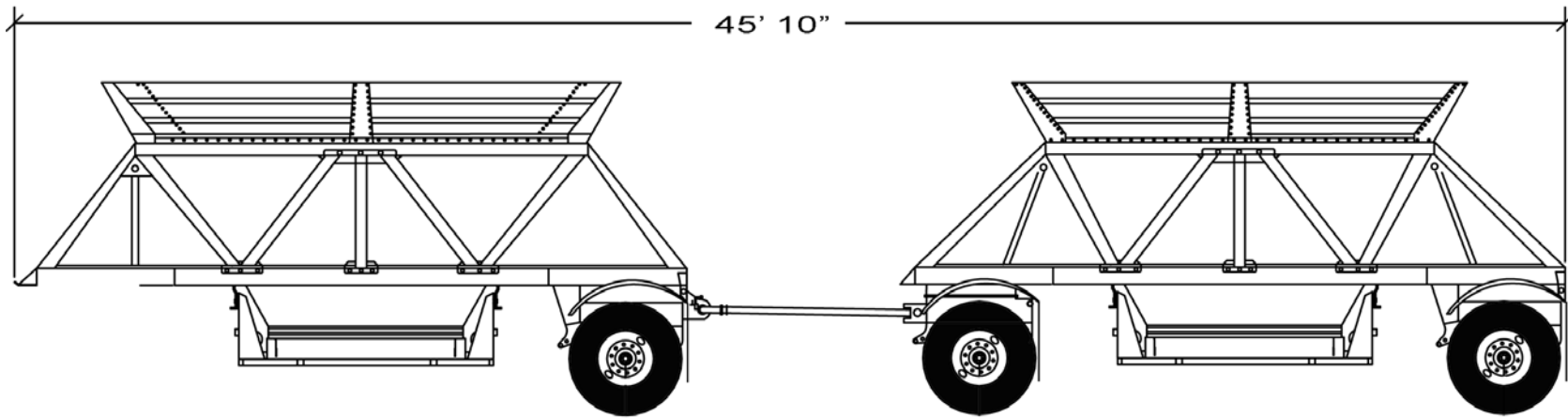

Capacity: 27.5 cubic yards (approx.) per set
Gates: Windrow Type;
Gate end: .190 aluminum 5052
Gate bottom: .190 aluminum 5052
Twin composite barrel air cylinder actuators
Adjustable chains front and rear
Skins: .125 aluminum 5052 drop in liner
Shedplates: 16 gauge aluminum
Fenders: Mill finish aluminum round (24x48) bolt on
Gate Controls: Versa Valve on left side, electrically actuated from truck cab
Gate Hoses: Hoses are 1/2" with one quick release valve per gate
Gate Seals: Aluminum welded on exterior of gate

Risers: .090 aluminum 5052 bolt on with 26" sides and flared ends
Electrical: DOT approved 12 volt sealed lighting system
Plumbing: DOT approved system
Under Mounts: Three leaf springs, 36" turntable bearing
Axles: 5" diameter - 71.5" track
Drums: Duralite with centrifuge drum
Brakes: ABS braking system, 16.5"x7"
S-cam type, auto slack adjusters
Drawbar: 131.5" long, square tubing, cast steel hinged bracket, rubber based, 2.375" ID swivel type eyebolt with safety cable
Tires: 11.22.5
Wheels: Aluminum mill finish

Ranco reserves the right to change designs, materials and specifications without notice or incurring any obligation to such change.

RANCO TRAILERS • P.O. BOX 856 • LAMAR, COLORADO 81052
(719) 336-9041 • FAX (719) 336-5952 • USA TOLL FREE 800-631-5708