

RANCO

PREMIER SERIES

Lightweight

BOTTOM DUMP TRAILERS

simply the best



Designed for Highway & Plant-to-Plant Hauling
with Maximum Payload Every Trip.

RANCO PREMIER SERIES EXCLUSIVE EXTRAS:

- Custom Built to your specifications
- Free 1-Year Scheduled Maintenance
- 3-Year Structural Warranty



Premier Series Lightweight Bottom Dump

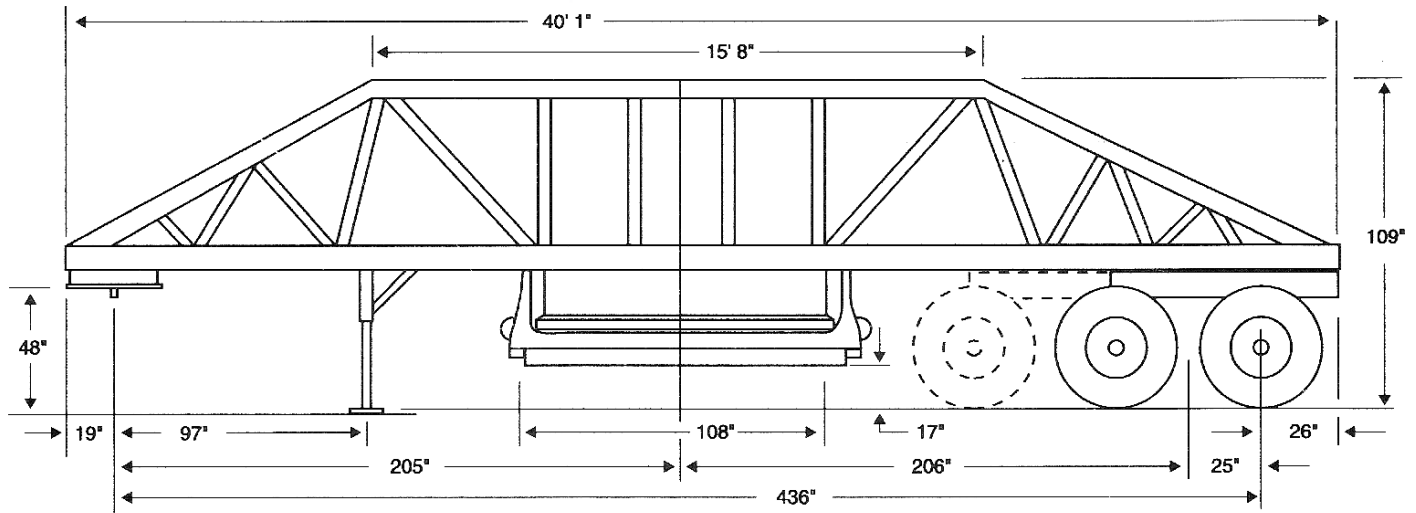

DESIGN YOUR OWN LIGHT WEIGHT TRAILER

- Six Different Lengths — 28 ft., 35 ft., 37 ft., 40 ft., 42 ft., & 44 ft.
- Two Capacities — 19 Cubic Yard or 21 Cubic Yard
- H-9700 Suspension — Tandem or Tri-axle Configuration — 3 Leaf or Single Leaf Springs
- Dual or Single Tire Configuration on Steel or Aluminum Wheels — PSI -Air System Available
- Upper Hopper Sheeting — AR-250 10 gauge, 12 gauge or 14 gauge — Insulated or Non-Insulated
- Lower Hopper Opening — 50" x 90" or 60" x 108" — Insulated or Non-Insulated
- Gate Face Material — AR-250 10 gauge or 12 gauge
- Lower Hopper Extensions — Reinforced Steel or Rubber
- Gate Seals — Steel and/or Rubber
- Gate Controls — Four (4) Different Brands
- Parking Legs — Telescoping or Removable
- Bolt On Fiberglass Front Fenders — Standard, Extended or None
- Windrow Deflectors
- Top-Off's — Aluminum, Steel or Wood in 3 Different Heights
- Tarps — Sliding or Flip Type
- Special Paint to Match Your Truck

RAHCO PREMIER SERIES FEATURES:

- Rubber Bushed Oscillating King Pin Plate — Never needs grease!
- Bolt on Rear Fenders — Easy to repair!
- 7" OR 8" Gate Cylinders — Plenty of Opening Power
- Filter and Lubricator in Protected Location
- Pin Setting Gate Equalizers — No Chains to fool with
- 22,500 lb. 5" Tubular Axles with Stemco Oil Seals
- Outboard Hub-Piloted Hubs with Centrifuge Drums
- 16 1/2 x 7" Air Brakes with Automatic Slack Adjusters
- 16 ply Radial Tires
- 4S-2M ABS Brake System
- Circuit Breaker Protected Sealed Beam Lights
- Wiring in Loom and Enclosed in Trailer Frame
- Sealed Document Holder