

RANCO

LIGHTWEIGHT

END DUMP

simply the best



RANCO LIGHTWEIGHT MT 36-38

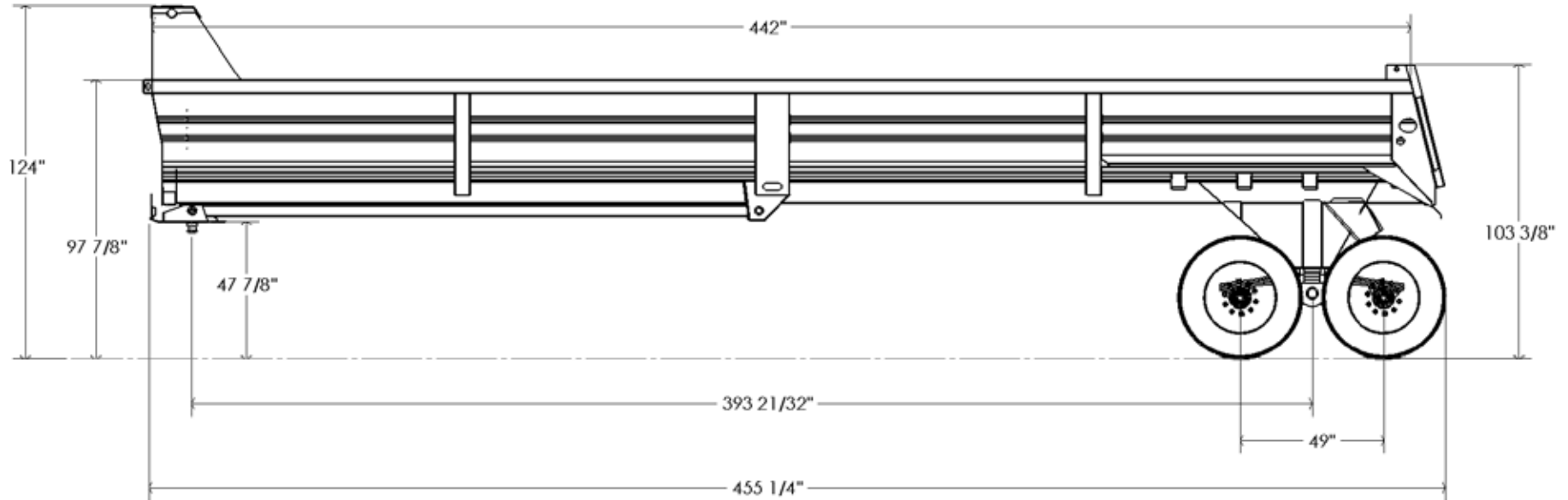

Ranco MT36-38 Standard Components:

- Parking Legs
- Rear Fenders
- Rockwell 22,500 lb. 5" Tubular Axel w/Stemco Seals
- 16.5" x 7" Air Brakes w/Auto Slack Adjusters
- Rockwell-Wabco 4S2M ABS Brake System
- Outboard Hubs w/ Centrifuge Drum
- 8.25 x 24.5 Steel Disc Wheels
- 11R24.5 Tires
- Circuit Breaker Protected Sealed Beam Lights
- Wiring in Loom and Enclosed in Trailer Frame
- Sealed Document Holder
- Ranco Artic White Paint
- Empty Weight-12,400 lbs.



36 Cubic Yard Loading Capacity

Ranco reserves the right to change designs, materials and specifications without notice or incurring any obligation to such change.

**RANCO TRAILERS • P.O. BOX 856 • LAMAR, COLORADO 81052
(719) 336-9041 • FAX (719) 336-5952 • USA TOLL FREE 800-631-5708**